



HARRLEX PROPERTY GROUP



THE CHEVRON

4 2 2

\$674,100

Build Price \$457,650
Land Price \$226,450

LOT 7248 PENDOWNER WAY, WERRIBEE
HARPLEY ESTATE

EST. TITLE DATE TITLED
HOME SIZE 20 SQ
LAND SIZE 242 m²

LAND PRICE INCLUDES \$10K REBATE AT SETTLEMENT

TURNKEY INCLUSIONS

- Full Turnkey
- 2590mm High Ceilings
- Holland Roller blinds and fly screens
- 20mm stone benchtop to kitchen with waterfall edge
- Timber laminate flooring to living area
- Split system heating and cooling to Living
- Premium Splashback to Kitchen
- Coloured Concrete Driveway
- Landscaping and Fencing
- Letterbox and Clothesline
- Quality carpet to bedrooms
- LED Downlights

FOR MORE INFORMATION EMAIL: info@harrlex.com.au



THE CHEVRON

4 2 2

\$674,100

Build Price \$457,650
Land Price \$226,450

LOT 7248 PENDOWNER WAY, WERRIBEE
HARPLEY ESTATE

EST. TITLE DATE TITLED
HOME SIZE 20 SQ
LAND SIZE 242 m²

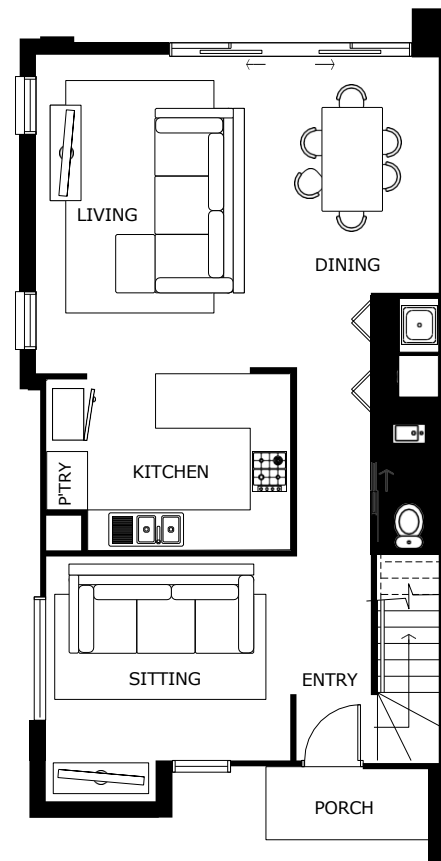
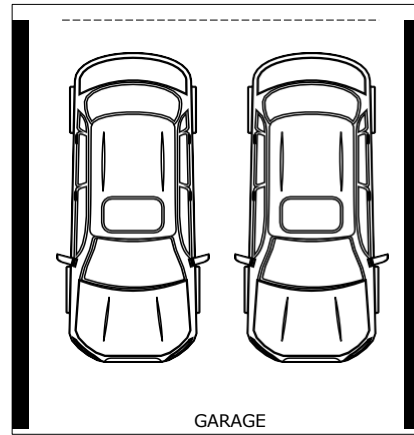

GROUND FLOOR

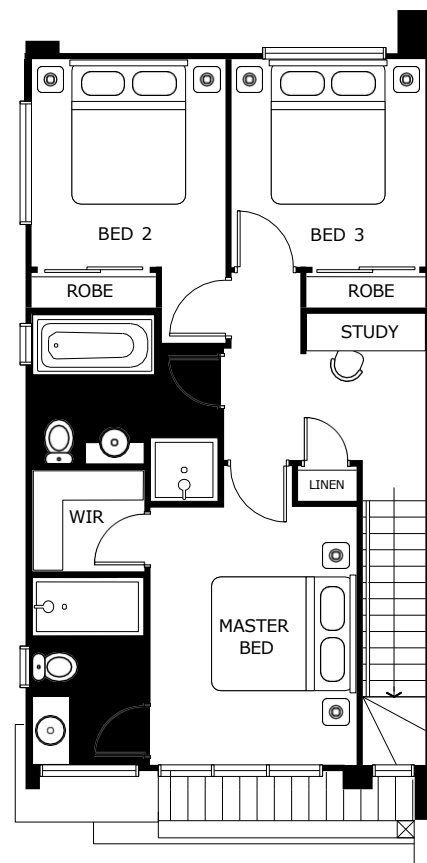

FIRST FLOOR

Whilst care has been taken in the preparation of this flyer, the particulars are not to be construed as containing any representation of the facts upon which any interested party is entitled to rely. This flyer is intended to provide general information only and does not constitute an offer to supply. All photographs, plans, maps and drawings are illustrative only and may not be to scale. Lot layout, lot size dimensions, easements, landscape treatments and final road layout are subject to change and conditional on authority approval. All interested parties should make their own enquires. Information contained is correct at the time of printing. * Source: Victorian Planning Authority CDB-U 50036

**IT'S ALL
INCLUDED!**

TURNKEY INCLUSIONS



INTERNAL FEATURES

Ceiling Height: 2590mm ceiling height (nominal) to single storey with 75mm cove cornice. 2590mm ceiling height (nominal) to ground floor of double storey homes, 2440mm ceiling height (nominal) to first floor, 75mm cove cornice throughout.

Room Doors: Flush panel Honeycomb Core 2040mm high to single storey, 2040mm high to ground floor and first floor of double storey.

Room Door Furniture: Passage set. Provide Alba Chrome levers through Chrome finish.

Mouldings: Skirtings – 67x18mm square edge primed MDF. Architraves – 67x18mm square edge primed MDF.

Plaster: Ceiling Plaster. 10mm plasterboard finish

Wall Plaster: Plasterboard 10mm thick. Water resistant plasterboard to Ensuite, Bathroom and above Laundry trough.

PAINT

Internal and External: Two coats.

HEATING

Panel heating unit installed to living areas and bedrooms (excludes wet areas and areas with split systems) as per manufacturers/suppliers recommendations for home size.

HOT WATER SYSTEM

Hot water unit in accordance with estate design guidelines.

KITCHEN

Fisher & Paykel oven 600mm.
Fisher & Paykel cooktop 600mm 4 burner stainless steel gas cooktop.
Fisher & Paykel rangehood 600mm stainless steel.
Fisher & Paykel dishwasher 600mm.

Sink: Stainless steel double bowl sink.

Tap: Mixer gooseneck in chrome finish.

Bench Top: Engineered stone benchtop 20mm. Choose colour from HATTAN colour scheme.

Splashback: Mirror. Choose colour from HATTAN colour scheme.

BATHROOM, ENSUITE, POWDER ROOM & WC

Mirror: Polished edges to full width of vanities sitting on 200mm tile splashback.

Basin: Ceramic above mount 440mm round, 120mm high, no tap hole low profile square inset basin (white), chrome waste 1 tap hole/overflow.

Vanity Unit: Floating vanity unit on tiled pedestal.

Bench Top: Engineered stone benchtop 20mm. Choose colour from HATTAN colour scheme.

Bath: 1525/1675mm acrylic bath (white) in tiled podium. (Design Specific)

Shower Bases: Ceramic tiled shower base. Selection from HATTAN colour scheme range with Stainless Steel Centre Waste.

Shower Screens: 1950mm high semi frameless with pivot door and clear laminated glass.

Taps and Outlets: Ensuite – Shower hand shower on rail. Bathroom Shower – Shower hand shower on rail. Bath (Wall Mounted) – Straight wall bath outlet and wall mixer. Basin (Wall Mounted) – Wall mixer.

Accessories: Toilet roll holders chrome and double towel rails.

Toilet Suite: China toilet suite in white with soft close seat.



LAUNDRY

Trough: 45 litre single inset bowl stainless steel without top bypass.

Base Cupboard: 800mm wide fully lined modular cabinet, refer to working drawings.

Bench Top: Laminate with square edge.

Tapware: Sink mixer in chrome finish.

ELECTRICAL

Internal Light Points: Recessed LED downlight in white non-metallic polyamide housing with diffuser.

External Light Points: (2 No) flood light wall mounted light fitting.

Power Points: White surround, double power points throughout excluding dishwasher, microwave and refrigerator provision.

Smoke Detector: Hardwired with battery backup.

Exhaust Fans: Above all showers not opening to outside air, 250mm with self-sealing air flow draft stoppers.



TV Points: To Family and Master Bedroom.

Telephone Point: To Kitchen and Master Bedroom.

Safety Switch: Residual Current Devices safety switch and circuit breakers to meter box.

PLUMBING

(2 No) garden taps, one located to the front water meter and one adjacent the external Laundry door.

TILING

Ceramic Floor Tiles: Selected from HATTAN colour scheme 400x400mm to Laundry, Ensuite, Bathroom, WC, Internal Courtyard and Powder room.

Ceramic Wall Tiles: Selected from HATTAN colour scheme 400x400mm to Laundry, Ensuite, Bathroom, WC, Powder room, shower recesses and above bath.

FLOOR COVERINGS

Carpet: Selected from HATTAN colour scheme to Bedrooms, WIR, Activity and Staircase.

Timber Laminate: Selected from HATTAN colour scheme timber look laminate flooring to Entry, Kitchen, WIP, Meals, Family, Living, Rear Hallway, Lounge and Study.

STORAGE

Shelving: Robes – One white melamine shelf and hanging rail.

Walk in Robe – One white melamine shelf and hanging rail.

Pantry/Linen – Four white melamine shelves.

Broom – One white melamine shelf.

Robe Doors: Single Storey – 2040mm high flush panel hinged doors.

STAIRS (DOUBLE STOREY HOMES)

Plaster dwarf walls to stairs and void areas with painted timber handrail (refer to staircase layout).

CAR ACCOMMODATION

Garage Door: Colorbond sectional door in flat line profile.

Remote Control: Remote control unit to front garage door with 2 handsets.

OUTDOOR

Landscaping: Garden and plants to the front and rear. Instant turf to rear yard. Or as per landscape design on drawings.

Fencing: 1800mm high timber paling/Colorbond including wing fence and gate to suit estate design covenants.

Paving: Coloured concrete to driveway and front path.

Letterbox: Pre cast concrete letterbox with colour to match house.

Clothesline: Fold out clothesline in rear yard.

